

### EXPORT

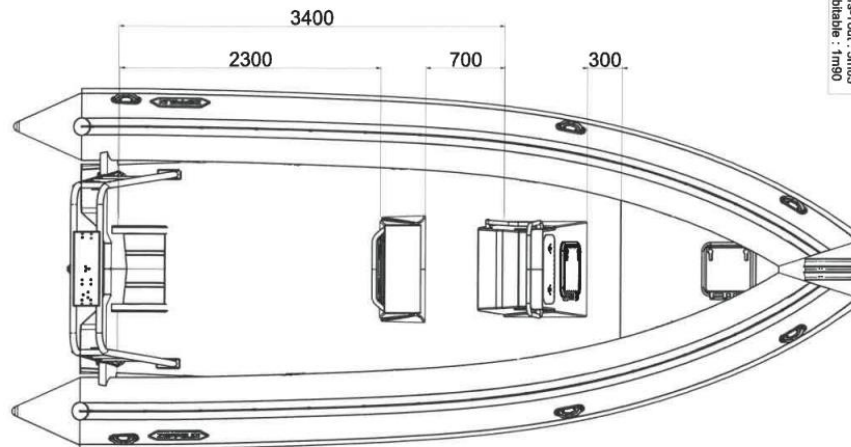

Longueur Hors-Tout : 7m50  
 Longueur Habitable : 6m10  
 Largeur Hors-Tout : 3m05  
 Largeur Habitable : 1m90

#### Technical Specifications

Overall length L H	7.50 m
Inside length	6.10 m
Overall width L H	3.10 m
Inside width	1.90 m
Number of chambers	7
Inflation valves	7
Buoyancy tube diameter	0.59 m
Light mass	1 573 kg
Lightship weight	2 090 kg
Full load weight	3 652 kg
Number of people in C	18
Neoprene hypalon float	1 670 dTex
Engine	
Fuel	Petrol
Engine type	Outboard
Engine shaft	Ultra Long
Max engine power	350 cv
Recommended engine power	250 cv
Max engine weight	346 kg
Trailer	
Recommended payload	1 800 kg



#### EXAMPLE OF CONFIGURATION :

- Deck hatch
- Console C800
- Bolster IOII
- Roll bar RB7
- Triple nose reinforcement
- 230L tank
- Engine DF 250 APX SUZUKI